



**HERVISA
PERLES**

ES A08 904 617

C/ Guifré el Pilós 1 bis
08213 - Polinyà (Spain)



TYPES / MODELS

e-POWER 2T

TRIFÁSICO / THREE PHASE

400V_50/60Hz



	(E) Manual del Operador
	(GB) Operators Manual
	(F) Manuel De L'Opérateur
	(S) Bruksanvisning
	(PL) Instrukcja Obsługi
	(RUS) Руководство для оператора
	(LT) Naudojimo Instrukcija
	(RO) Manual de Utilizare
	(NO) Betjene Håndbok
	(CZ) Na'vod K Obsluze
	(D) Bedienungshandbuch
	(BG) Упътване за употреба
	(P) Manual do usuário



**DATOS TÉCNICOS
TECH DATA**



**WEB/WEBSITE
WWW.HERVISAPERLES.COM**



x2

42V_200



EP2T-26/04



* SEGURIDAD ELECTRICA * ELECTRICAL SAFETY * SECURITE ELECTRIQUE *
 ELEKTRISK SAKERHET * BEZPIECZENSTWO ELEKTRYCZNE * ЭЛЕКТРИЧЕСКАЯ
 БЕЗОПАСНОСТЬ * DARBO SU ELEKTRINIAIS * SIGURANTA ELECTRIC *
 ELEKTRISK SIKKERHET * ELEKTRICKYM NARADIM * ELEKTRISCHE SICHERHEIT *
 ЭЛЕКТРИЧЕСКА БЕЗОПАСНОСТ * SEGURANÇA ELÉTRICA

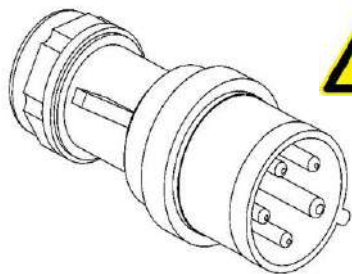

400V

3P+T  16A

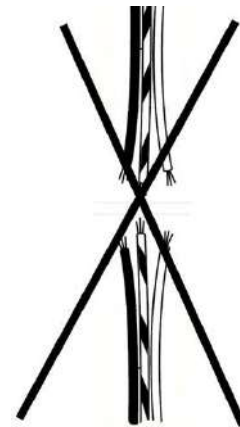
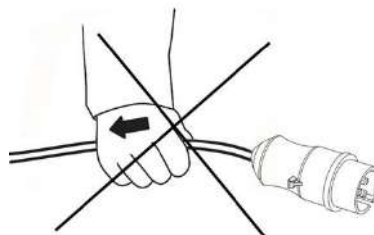
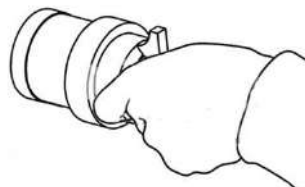

- *Precaución: Red con toma tierra
- *Warning: Grounding electrical network
- *Attention: Réseau électrique à la terre
- *Varning: Elnätet elektrisk jordning
- *Uwaga: Sieć elektryczna uziemienia
- *Внимание: сети электрического заземления
- *Atsargiai: Maitinimo elektros įžeminimo
- *Atenție: Rețea de împământare electrică
- *Advarsel: Stikkontakt grunnstøting
- *Upozornění: Napájecí elektrické uzemnění
- *Achtung: Netz elektrischen Erdung
- *Внимание: Заземлена электрическа мрежа
- *Cuidado: Rede aterrada

WARNING



* PROTEGIDO * PROTECTED * PROTÉGÉ * SKYDDAD * OCHRONNY * ОХРАНЯЕМЫХ * SAUGOMA *
 * PROTEJATE * BESKYTTET * CHRÁNĚNÉ * GESCHÜTZT * ЗАЩИТЕНИ * PROTEGIDO *



E. P. A.

AUSENCIA TOMA TIERRA
 ABSENCE GROUNDING CONNECTION
 Mise à la terre L'ABSENCE
 FRÅNVARO JORDNING ANSLUTNING
 Uziemieniem BRAKU
 ОТСУТСТВИЕ заземления
 NEDARBINGUMAS dangai susijungian
 Absenta împământare connection
 FRAVÆR JORDING TILKOBLING
 ABSENCE uzemnění
 KEINE Erdung
 Липсата ЗАЗЕМЯВАНЕ ВРЪЗКА
 AUSÊNCIA TOMA TERRA

TENSION E INTENSIDAD
 VOLTAGE AND CURRENT
 TENSION ET COURANT
 Spännings-och
 NAPIĘCIA I PRĄDU
 Напряжение и ток
 Įtampos ir srovės
 De tensiune și curent
 Spenning og strøm
 NAPĚTÍ A PROUDU
 SPANNUNG UND STROM
 Напрежението и тока
 TENSÃO E INTENSIDADE

SOBRECALENTAMIENTO
 OVERHEATING
 SURCHAUFFE
 ÖVERHETTNING
 PRZEGRZANIA
 ПЕРЕГРЕВА
 Perkaitimas
 SUPRĂÎNCĂLZIRE
 OVEROPPHETING
 PŘEHŘÁTÍ
 ÜBERHITZUNG
 ПРЕГРЯВАНЕ
 SUPERAQUECIMENTO



* MEDIO AMBIENTE * ENVIRONMENT * ENVIRONNEMENT * MILJÖ *
ŚRODOWISKO * ОКРУЖАЮЩЕЙ СРЕДЫ * APLINKA * MEDIU * MILJØ *
ZIVOTNI PROSTREDI * UMWELTSCHUTZ * ОКОЛНА СРЕДА * AMBIENTE *

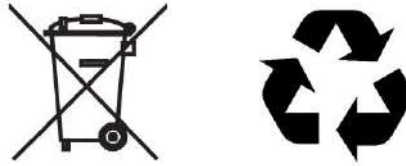

* SEGURIDAD GENERAL * GENERAL SAFETY * GENERALE DE SECURITE * ALLMÄN
SÄKERHET * BEZPIECZEŃSTWA * ОБЩАЯ БЕЗОПАСНОСТЬ * BENDROSIOS SAUGOS *
SIGURANTA * GENERELL SIKKERHET * OBECNE EZPECNOSTNI POKYNY * ALLGEMEINE
SICHERHEIT * ОБЩА БЕЗОПАСНОСТ * SEGURANÇA GERAL *



* AREA DE TRABAJO * WORK AREA * ZONE DE TRAVAIL *
ARBETSOMRADE * OBSZAR ROBOCZY * РАБОЧЕЕ МЕСТО * DARBO
VIETA * ZONA DE LUCRU * ARBEIDSOMRADE * PRACOVISTE *
ARBEITSUMFELD * РАБОТНО МЯСТО * ÁREA DE TRABALHO *



* QUICK VIE *



BASES CONEXION
Outlets

ASA DE TRANSPORTE
Handle

CABLE DE RED
Network cable



CONVERTIDOR ELECTRONICO
Electronic drive unit

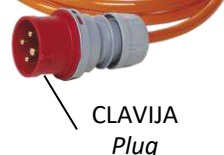

CLAVIJA
Plug



Conexión de agujas
Poker connections:
AV - AV Turbo
Ergo - Ergo Turbo

1

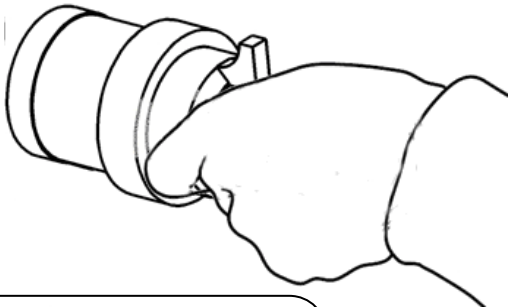

CAUTION



400V / 50-60Hz

2

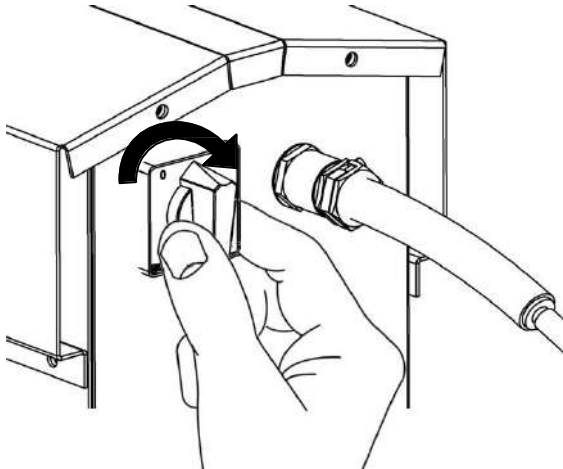

3

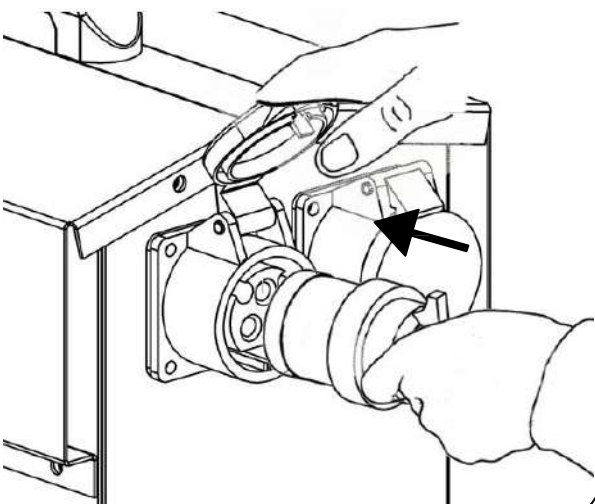

4

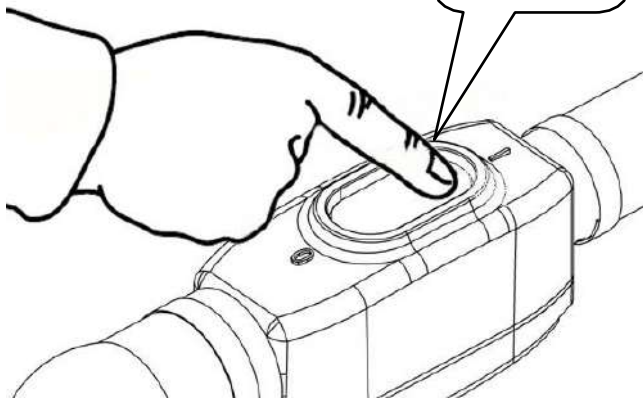

ON

Hervisa, s.a. 
 ES A08 904 617

E-POWER 2T

CODE
10468

 2 x 3Ph - 42V/200Hz

SERIAL N°.: **006923**

MADE IN EU

INPUT
3Ph x 400V - 50/60Hz - 7A

OUTPUT
3Ph x 42V / 200Hz - 30A
3 kVA

IP44

DATE:
20/06/24

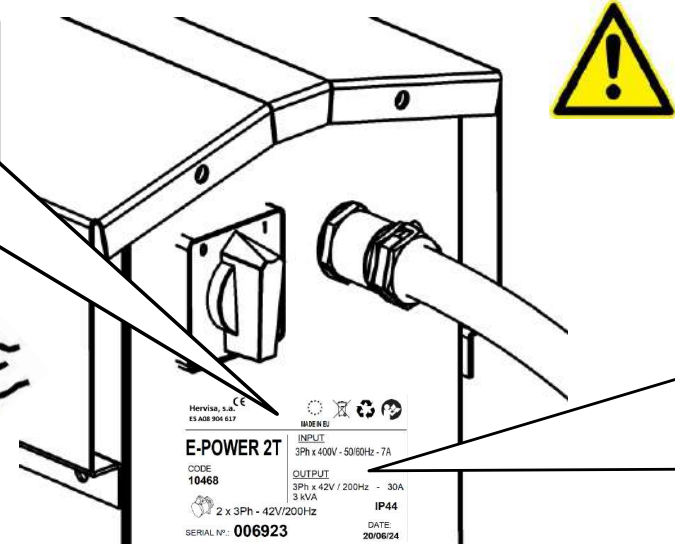

E-POWER 2T

CODE
10468

 2 x 3Ph - 42V/200Hz

SERIAL N°.: **006923**

MADE IN EU

INPUT
3Ph x 400V - 50/60Hz - 7A

OUTPUT
3Ph x 42V / 200Hz - 30A
3 kVA

IP44

DATE:
20/06/24

CAUTION

AV 385 TURBO 38	2
AV 425 TURBO 42	2
AV 525 TURBO 52	2
AV 585 TURBO 58	2
AV 655 TURBO 65	2
AV 755 TURBO 75	1

MAXIMUM RECOMMENDED POKER CONNECTIONS

E-POWER 2T

 Hervisa, s.a.
 ES A08 904 617

OUTPUT

3Ph x 42V / 200Hz

30A - 3,0 kVA

* SERVICIO Y MANTENIMIENTO * SERVICE AND MAINTENANCE * ENTRETIEN ET REVISION * SERVICE & UNDERHALL * SERWIS I KONSERWACJA * СЕРВИС И ОБСЛУЖИВАНИЕ * TECHNINE PRIEZIURA * SERVICE SI INTRETINERE * SERVICE OG VEDLIKEHOLD * SERVIS A UDRZBA * SERVICE AND WARTUNG * ОБСЛУЖВАНЕ И ПОДДРЪЖКА * SERVIÇO E MANUTENÇÃO *

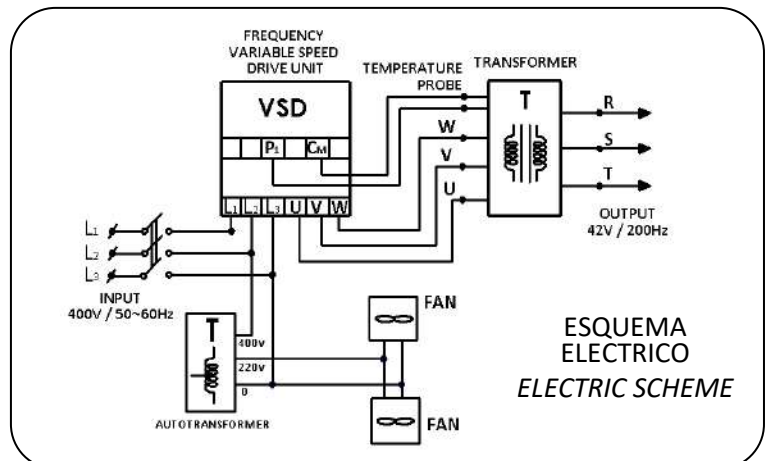
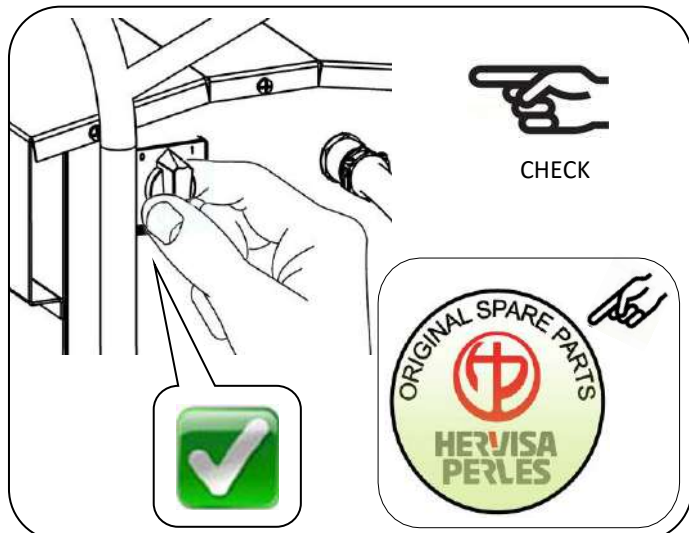
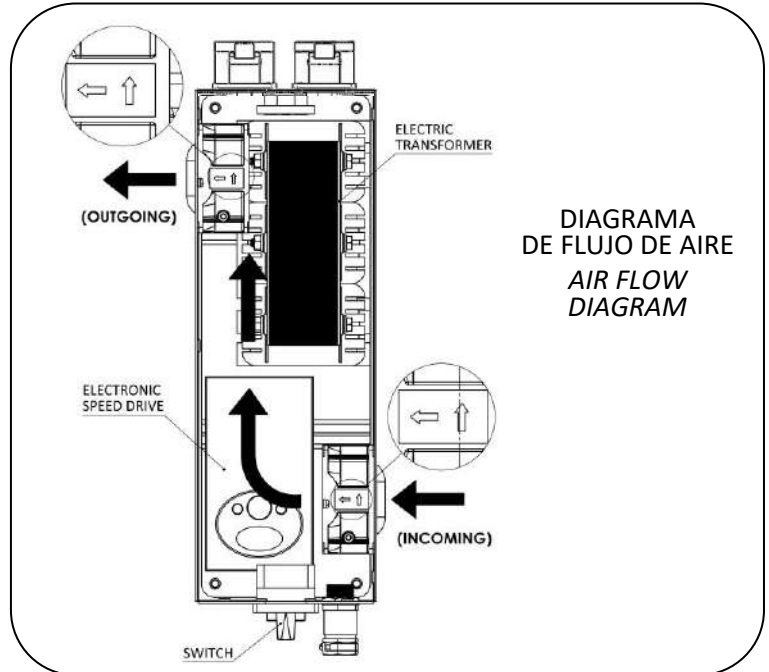
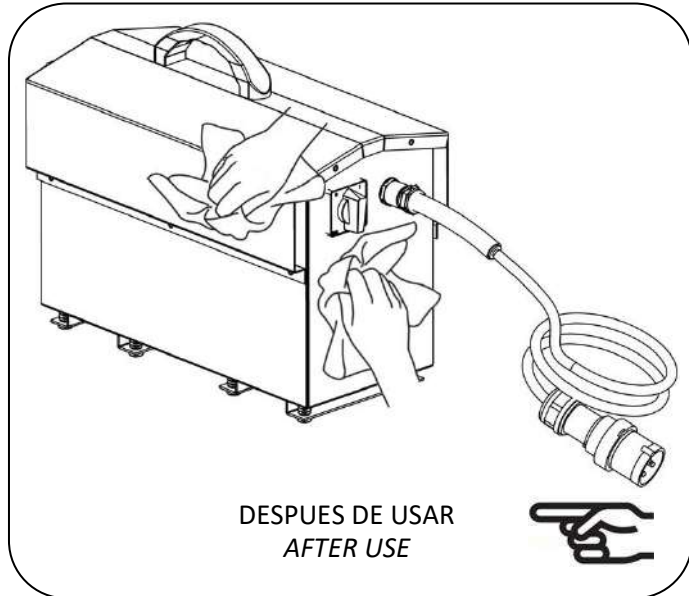
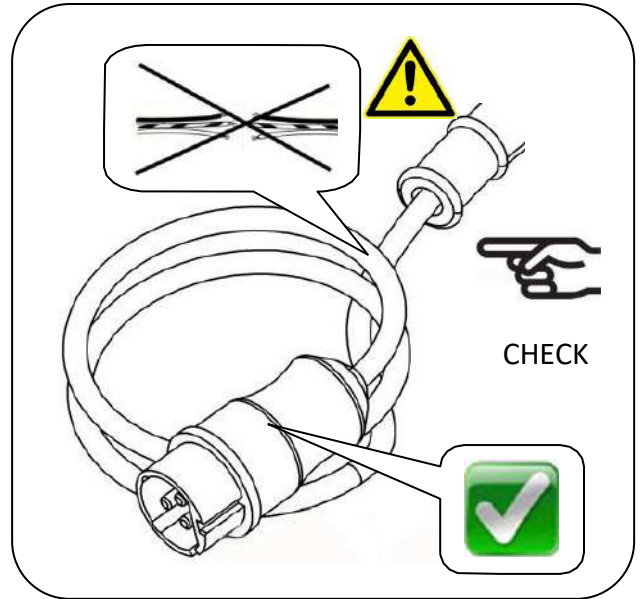
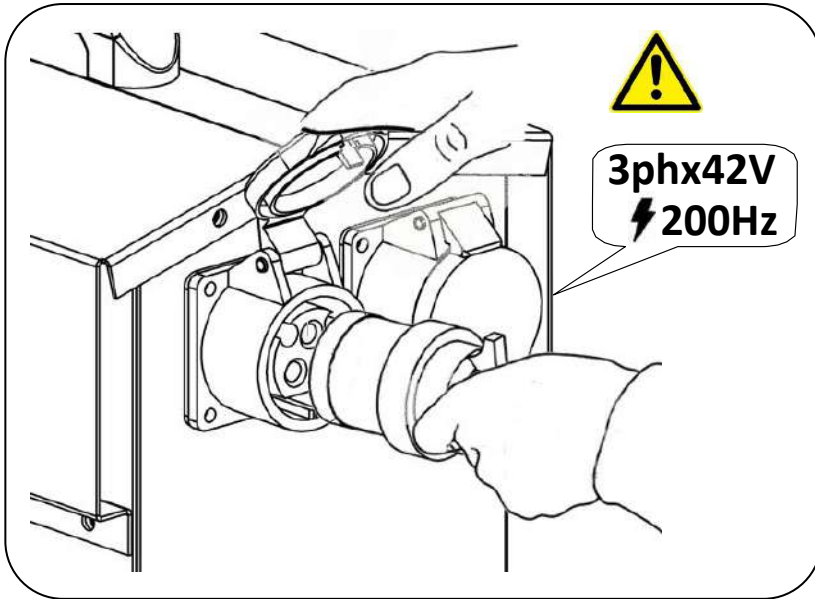



* ALMACENAJE Y TRANSPORTE * STORAGE & TRANSPORTATION *

* STOCKAGE ET TRANSPORT * FÖRVARING OCH TRANSPORT *

* MAGAZYNOWANIE I TRANSPORT *

* ХРАНЕНИЕ И ТРАНСПОРТИРОВКА (KHRANENIYe I TRANSPORTIROVKA) *

* LAIKYMAS IR TRANSPORTAVIMAS * DEPOZITARE ŞI TRANSPORT *

* LAGRING OG TRANSPORT * SKLADOVÁNÍ A PŘEPRAVA * LAGERUNG UND TRANSPORT *

* СЪХРАНЕНИЕ И ТРАНСПОРТ (SŪKHRANENIE I TRANSPORT) * ARMAZENAMENTO E TRANSPORTE *

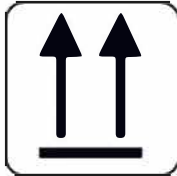
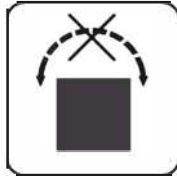

WARRANTY

* GARANTIA * WARRANTY * GARANTIE * GARANTI * GWARANCJA * ГАРАНТИЯ *

GARANTIJA * GARANTIA * GARANTI * ZARUKA * GARANTIE * ГАРАНЦІЯ * GARANTIA *



CONDICIONES DE GARANTÍA CONSULTE CON SU DISTRIBUIDOR.

WARRANTY CONDITIONS CONSULT WITH YOUR DISTRIBUTOR.

CONDITIONS DE GARANTIE CONSULTEZ VOTRE CONCESSIONNAIRE.

GARANTIVILLKOR KONTAKTA DIN ÅTERFÖRSÄLJARE.

WARUNKI GWARANCJI NALEŻY SKONSULTOWAĆ Z DEALEREM.

УСЛОВИЯ ГАРАНТИИ ОБРАЩАЙТЕСЬ К ВАШЕМУ ДИЛЕРУ.

USLOVIYA GARANTII OBRASHCHAYTES' K VASHEMU DILERU.

GARANTIJOS SAĻYGOS. PASITARKITE SU SAVO ATSTOVU.

CONDIȚII DE GARANȚIE CONSULTAȚI DEALERUL.

GARANTIVILKĀR, KONTAKT DIN FORHANDLER.

ZÁRUČNÍ PODMÍNKY KONZULTUJTE S PRODEJCEM.

GARANTIEBEDINGUNGEN WENDEN SIE SICH AN IHREN HÄNDLER.

ГАРАНЦІОННИ УСЛОВІЯ КОНСУЛТИРАЙТЕ СЕ С ВАШИЯ ДИЛЪР.

GARANTSIONNI USLOVIYA KONSULTIRAITE SE S VASHIYA DILŪR.

CONDIÇÕES DE GARANTIA CONSULTE O SEU REVENDEDOR.

