



**HERVISA  
PERLES**

ES A08 904 617

C/ Guifré el Pilós 1 bis  
08213 - Polinyà (Spain)



**TYPES / MODELS**

# e-POWER 2M

**MONOFÁSICO / SINGLE PHASE**  
**230V\_50/60Hz**



-  (E) Manual del Operador
-  (GB) Operators Manual
-  (F) Manuel De L'Opérateur
-  (S) Bruksanvisning
-  (PL) Instrukcja Obsługi
-  (RUS) Руководство для оператора
-  (LT) Naudojimo Instrukcija
-  (RO) Manual de Utilizare
-  (NO) Betjene Håndbok
-  (CZ) Na'vod K Obzluze
-  (D) Bedienungshandbuch
-  (BG) Упътване за употреба
-  (P) Manual do usuário



**DATOS TÉCNICOS**  
**TECH DATA**



**WEB/WEBSITE**  
**WWW.HERVISAPERLES.COM**



**x2**

**42V\_200Hz**



EP2-26/04



\* SEGURIDAD ELECTRICA \* ELECTRICAL SAFETY \* SECURITE ELECTRIQUE \*  
 ELEKTRISK SAKERHET \* BEZPIECZENSTWO ELEKTRYCZNE \* ЭЛЕКТРИЧЕСКАЯ  
 БЕЗОПАСНОСТЬ \* DARBO SU ELEKTRINIAIS \* SIGURANTA ELECTRIC \*  
 ELEKTRISK SIKKERHET \* ELEKTRICKYM NARADIM \* ELEKTRISCHE SICHERHEIT \*  
 ЭЛЕКТРИЧЕСКА БЕЗОПАСНОСТ \* SEGURANÇA ELÉTRICA

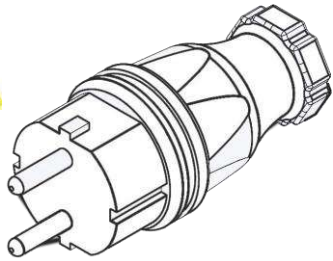

**230V**

2P +  $\perp$  16A

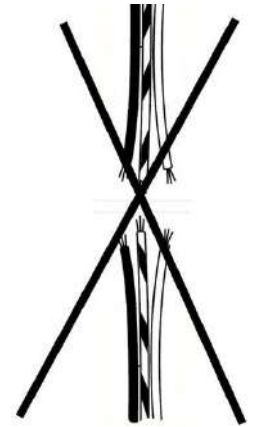
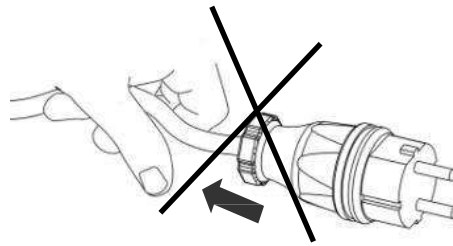
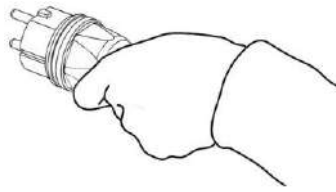

- \*Precaución: Red con toma tierra
- \*Warning: Grounding electrical network
- \*Attention: Réseau électrique à la terre
- \*Varning: Elnätet elektrisk jordning
- \*Uwaga: Sieć elektryczna uziemienia
- \*Внимание: сети электрического заземления
- \*Atsargiai: Maitinimo elektros įžeminimo
- \*Atenție: Rețea de împământare electrică
- \*Advarsel: Stikkontakt grunnstøting
- \*Upozornění: Napájecí elektrické uzemnění
- \*Achtung: Netz elektrischen Erdung
- \*Внимание: Заземлена электрическа мрежа
- \*Cuidado: Rede aterrada



\* PROTEGIDO \* PROTECTED \* PROTÉGÉ \* SKYDDAD \* OCHRONNY \* ОХРАНЯЕМЫХ \* SAUGOMA \*  
 \* PROTEJATE \* BESKYTTET \* CHRÁNĚNÉ \* GESCHÜTZT \* ЗАЩИТЕНИ \* PROTEGIDO \*



E. P. A.

AUSENCIA TOMA TIERRA  
 ABSENCE GROUNDING CONNECTION  
 Mise à la terre L'ABSENCE  
 FRÅNVARO JORDNING ANSLUTNING  
 Uziemieniem BRAKU  
 ОТСУТСТВИЕ заземления  
 NEDARBINGUMAS dangai susijungian  
 Absenta împământare connection  
 FRAVÆR JORDING TILKOBLING  
 ABSENCE uzemnění  
 KEINE Erdung  
 Липсата ЗАЗЕМЯВАНЕ ВРЪЗКА  
 AUSÊNCIA TOMA TERRA

TENSION E INTENSIDAD  
 VOLTAGE AND CURRENT  
 TENSION ET COURANT  
 Spännings-och  
 NAPIĘCIA I PRĄDU  
 Напряжение и ток  
 Įtampas ir srovės  
 De tensiune și curent  
 Spenning og strøm  
 NAPĚTÍ A PROUDU  
 SPANNUNG UND STROM  
 Напрежението и тока  
 TENSÃO E INTENSIDADE

SOBRECALENTAMIENTO  
 OVERHEATING  
 SURCHAUFFE  
 ÖVERHETTNING  
 PRZEGRZANIA  
 ПЕРЕГРЕВА  
 Perkaitimas  
 SUPRĂÎNCĂLZIRE  
 OVEROPPHETING  
 PŘEHŘÁTÍ  
 ÜBERHITZUNG  
 ПРЕГРЯВАНЕ  
 SUPERAQUECIMENTO



\* MEDIO AMBIENTE \* ENVIRONMENT \* ENVIRONNEMENT \* MILJÖ \*  
 ŚRODOWISKO \* ОКРУЖАЮЩЕЙ СРЕДЫ \* APLINKA \* MEDIU \* MILJØ \*  
 ZIVOTNI PROSTREDI \* UMWELTSCHUTZ \* ОКОЛНА СРЕДА \* AMBIENTE \*

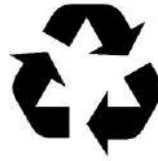

\* SEGURIDAD GENERAL \* GENERAL SAFETY \* GENERALE DE SECURITE \* ALLMÄN  
 SÄKERHET \* BEZPIECZEŃSTWA \* ОБЩАЯ БЕЗОПАСНОСТЬ \* BENDROSIOS SAUGOS \*  
 SIGURANTA \* GENERELL SIKKERHET \* OBECNE EZPECNOSTNI POKYNY \* ALLGEMEINE  
 SICHERHEIT \* ОБЩА БЕЗОПАСНОСТ \* SEGURANÇA GERAL \*



\* AREA DE TRABAJO \* WORK AREA \* ZONE DE TRAVAIL \*  
 ARBETSSOMRADE \* OBSZAR ROBOCZY \* РАБОЧЕЕ МЕСТО \* DARBO  
 VIETA \* ZONA DE LUCRU \* ARBEIDSOMRADE \* PRACOVISTE \*  
 ARBEITSUMFELD \* РАБОТНО МЯСТО \* ÁREA DE TRABALHO \*



## \* QUICK VIEW \*

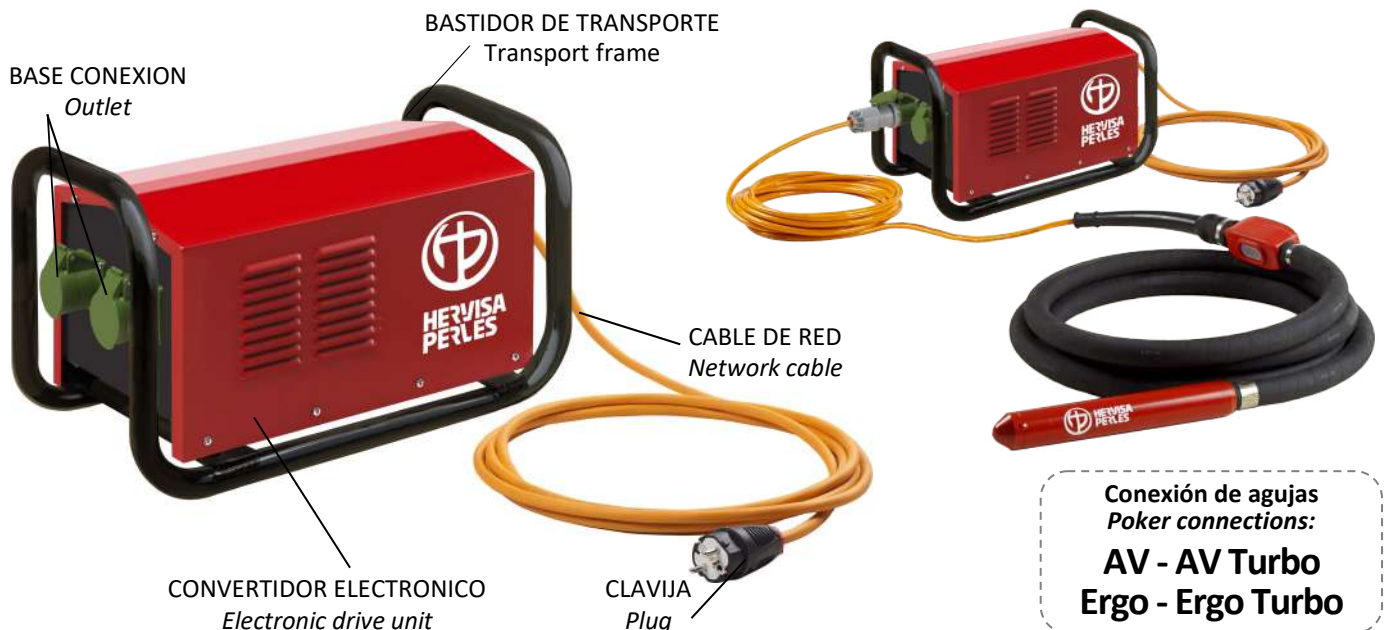

\* OPERATIVA \* OPERATION \* FONCTIONNEMENT \* DRIFT  
 \* PRACA URZADZENIA \* РАБОЧИЕ \* NAUDOJIMAS \* UTILIZAREA \* BRUK  
 \* POKYNY PRO PROVOZ \* HANDHABUNG \* ЕКСПЛУАТАЦІЯ \* OPERACIONAL \*

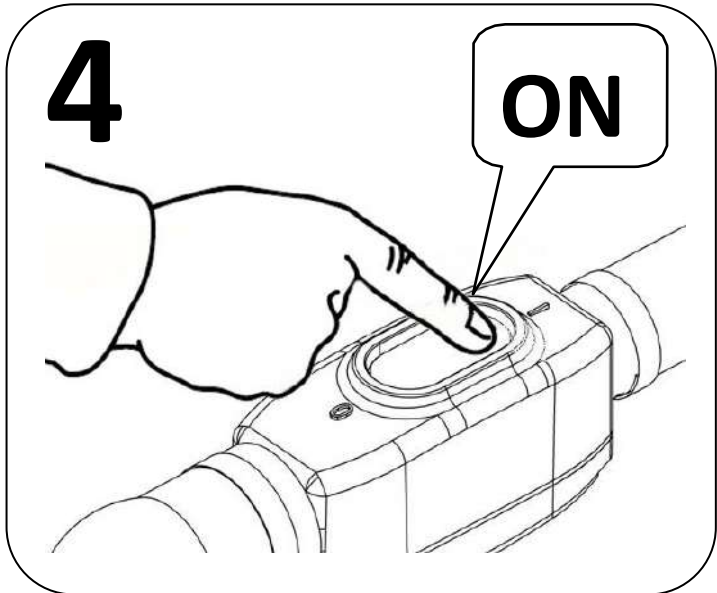
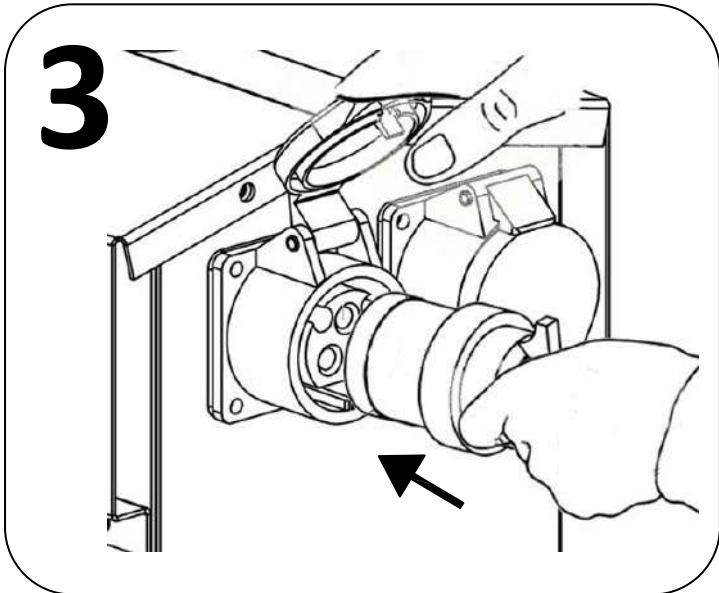
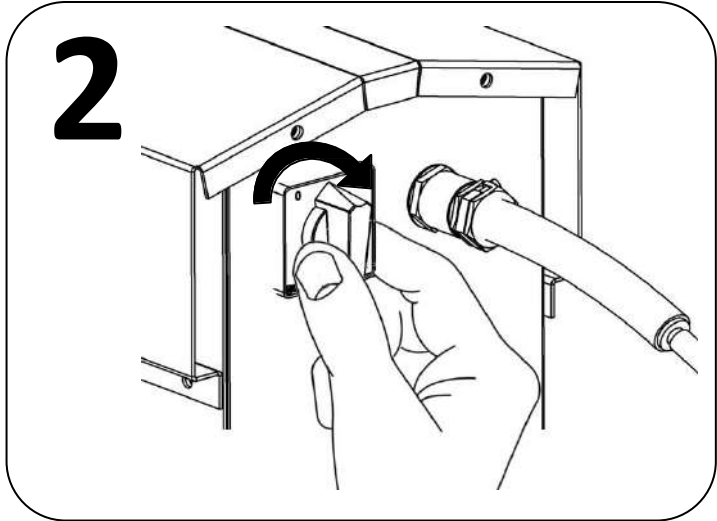
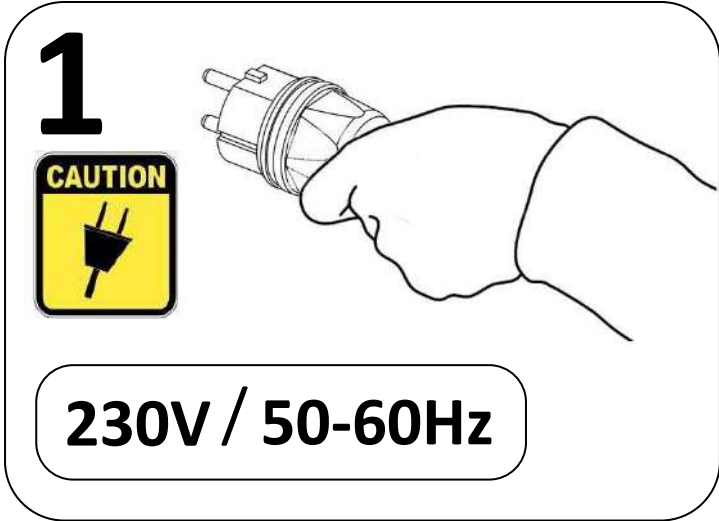

Hervisa, s.a. <sup>CE</sup>  
ES A08 904 617

**E-POWER 2M**

CODE **10172**

2x42V/200Hz

SERIAL N°: **007548**

MADE IN EU

INPUT  
230V - 50/60Hz - 7,5A / 1Ph

OUTPUT  
42V / 200Hz - 20A / 3Ph  
1,5 kVA

**IP44-57**

DATE:  
20/06/24

Hervisa, s.a. <sup>CE</sup>  
ES A08 904 617

**E-POWER 2M**

CODE **10172**

2x42V/200Hz

SERIAL N°: **007548**

MADE IN EU

INPUT  
230V - 50/60Hz - 7,5A / 1Ph

OUTPUT  
42V / 200Hz - 20A / 3Ph  
1,5 kVA

**IP44-57**

DATE:  
20/06/24

**CAUTION**

AV 385 TURBO 38	2
AV 425 TURBO 42	2
AV 525 TURBO 52	2
AV 585 TURBO 58	2
AV 655 TURBO 65	1
AV 755 TURBO 75	1

**E-POWER 2M**

<sup>CE</sup>  
Hervisa, s.a.  
ES A08 904 617

\* SERVICIO Y MANTENIMIENTO \* SERVICE AND MAINTENANCE \* ENTRETIEN ET REVISION \* SERVICE & UNDERHALL \* SERWIS I KONSERWACJA \* СЕРВИС И ОБСЛУЖИВАНИЕ \* TECHNINE PRIEZIURA \* SERVICE SI INTRETINERE \* SERVICE OG VEDLIKEHOLD \* SERVIS A UDRZBA \* SERVICE AND WARTUNG \* ОБСЛУЖВАНЕ И ПОДДРЪЖКА \* SERVIÇO E MANUTENÇÃO \*

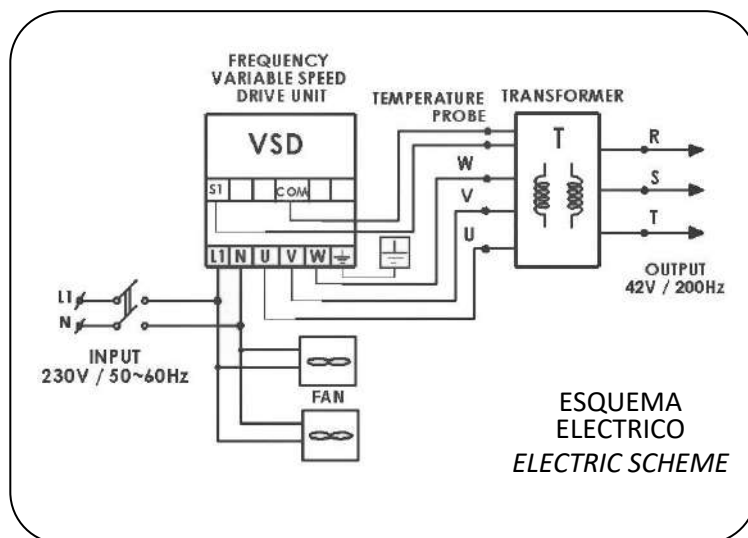
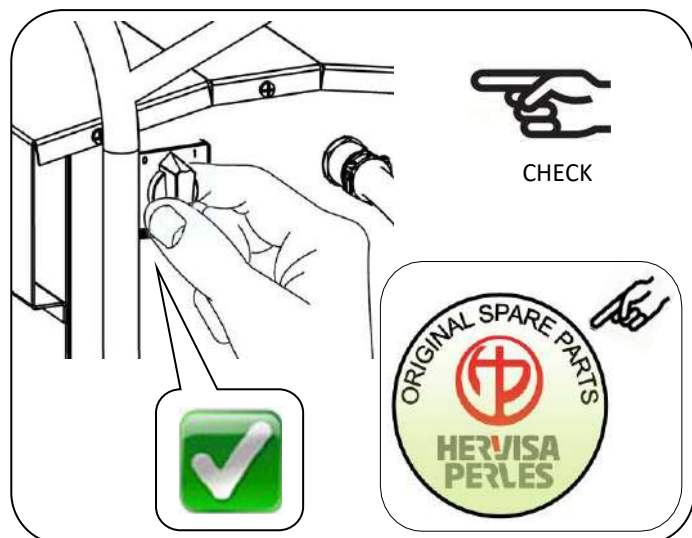
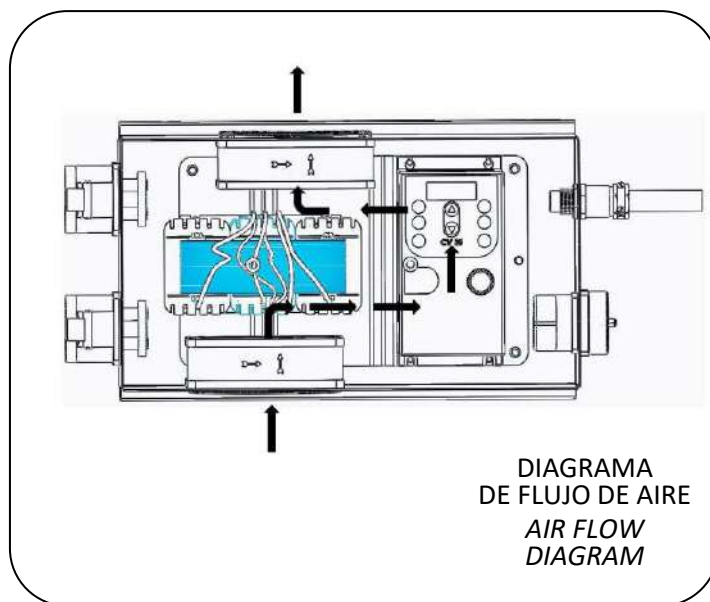
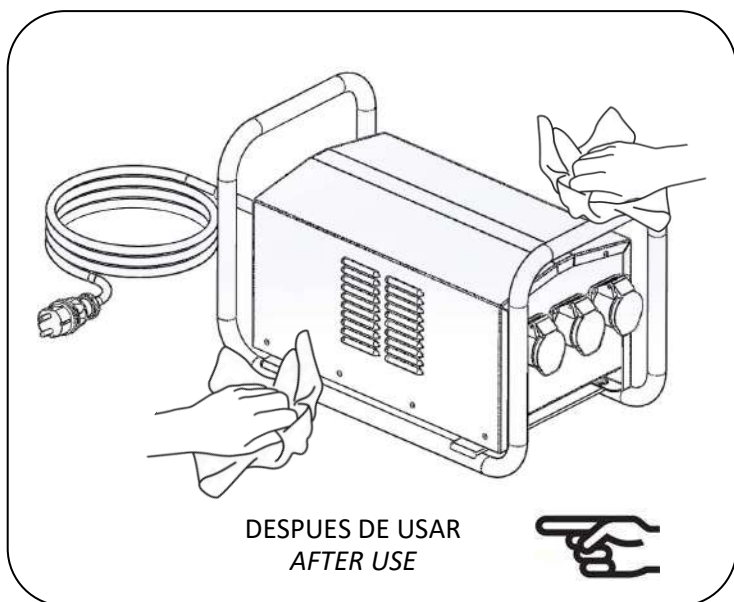
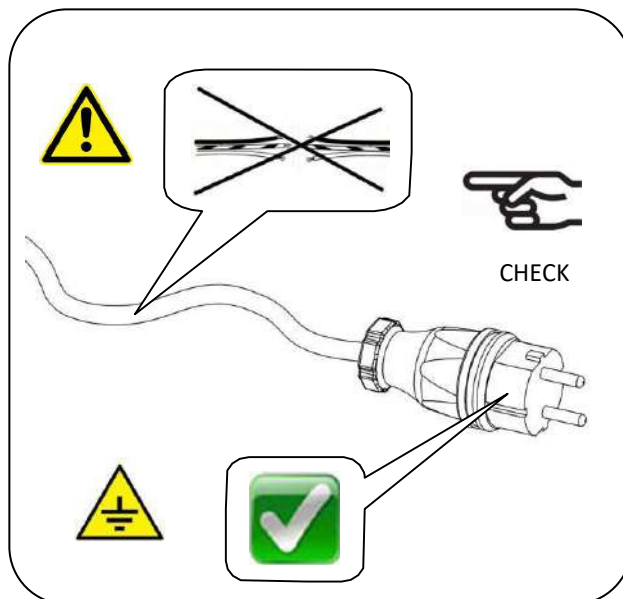
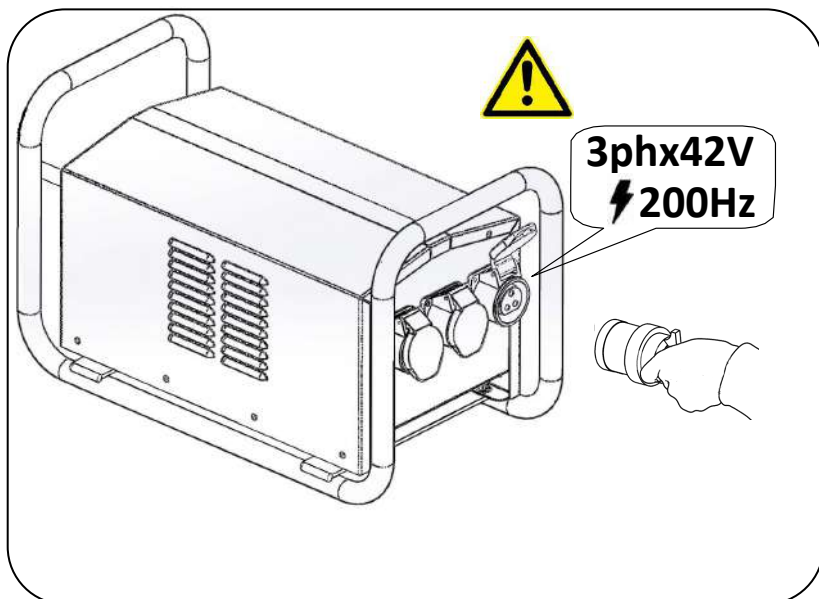



\* ALMACENAJE Y TRANSPORTE \* STORAGE & TRANSPORTATION \*

\* STOCKAGE ET TRANSPORT \* FÖRVARING OCH TRANSPORT \*

\* MAGAZYNOWANIE I TRANSPORT \*

\* ХРАНЕНИЕ И ТРАНСПОРТИРОВКА (KHRANENIYe I TRANSPORTIROVKA) \*

\* LAIKYMAS IR TRANSPORTAVIMAS \* DEPOZITARE ŞI TRANSPORT \*

\* LAGRING OG TRANSPORT \* SKLADOVÁNÍ A PŘEPRAVA \* LAGERUNG UND TRANSPORT \*

\* СЪХРАНЕНИЕ И ТРАНСПОРТ (SŪKHRANENIE I TRANSPORT) \* ARMAZENAMENTO E TRANSPORTE \*

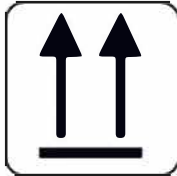
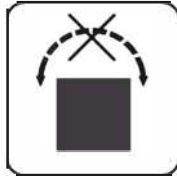

# WARRANTY

\* GARANTIA \* WARRANTY \* GARANTIE \* GARANTI \* GWARANCJA \* ГАРАНТИЯ \*

GARANTIJA \* GARANTIA \* GARANTI \* ZARUKA \* GARANTIE \* ГАРАНЦІЯ \* GARANTIA \*



**CONDICIONES DE GARANTÍA CONSULTE CON SU DISTRIBUIDOR.**

WARRANTY CONDITIONS CONSULT WITH YOUR DISTRIBUTOR.

**CONDITIONS DE GARANTIE CONSULTEZ VOTRE CONCESSIONNAIRE.**

GARANTIVILLKOR KONTAKTA DIN ÅTERFÖRSÄLJARE.

**WARUNKI GWARANCJI NALEŻY SKONSULTOWAĆ Z DEALEREM.**

УСЛОВИЯ ГАРАНТИИ ОБРАЩАЙТЕСЬ К ВАШЕМУ ДИЛЕРУ.

USLOVIYA GARANTII OBRASHCHAYTES' K VASHEMU DILERU.

**GARANTIJOS SAĻYGOS. PASITARKITE SU SAVO ATSTOVU.**

CONDIȚII DE GARANȚIE CONSULTAȚI DEALERUL.

**GARANTIVILKĀR, KONTAKT DIN FORHANDLER.**

ZÁRUČNÍ PODMÍNKY KONZULTUJTE S PRODEJCEM.

**GARANTIEBEDINGUNGEN WENDEN SIE SICH AN IHREN HÄNDLER.**

ГАРАНЦІОННИ УСЛОВІЯ КОНСУЛТИРАЙТЕ СЕ С ВАШИЯ ДИЛЪР.

GARANTSIONNI USLOVIYA KONSULTIRAITE SE S VASHIYA DILŪR.

**CONDIÇÕES DE GARANTIA CONSULTE O SEU REVENDEDOR.**

